

BACKFIRE

Volume 56 No 11 April 2023

PO Box 200 Newcomb VIC 3219

Club meetings: 7.30pm 2nd Tues each month. Clubroom: Geelong Showgrounds, 79 Breakwater Rd East Geelong.



Indian

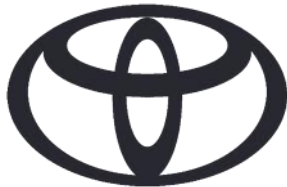

Norton



*Backfire is the monthly newsletter of the Western District Historic Vehicle Club (Reg No A00011857H).
Member of the Federation of Victorian Veteran, Vintage & Classic Vehicle Clubs.*



www.wdhvcgeelong.com



[WesternDistrictHistoricVehicleClub](https://www.facebook.com/WesternDistrictHistoricVehicleClub)



[wdhvc_car_club_geelong](https://www.instagram.com/wdhvc_car_club_geelong)

CONTENTS

HONORARY OFFICE BEARERS AND COMMITTEE - 2022/2023	2
CONTENTS & PRESIDENT'S IDLE CHATTER	3
MEETING MINUTES	4
MEETING MINUTES (ctd) & NOTICE OF AGM	5
20022 AGM MINUTES & 25 YEAR BADGES PRESENTED	6
ANSWWR TO THE BADGE MYSTERY	7
EVENTS CALENDAR & MEMBERSHIP RENEWAL REMINDER	8
EVENTS CALENDAR	9
RALLIES AND RUNS (Feb Tinker Day)	10
RALLIES AND RUNS (Feb Tech Night) & MARCH FEATURE CAR	11
WORLD SOLAR CHALLENGE 1987	12
WORLD SOLAR CHALLENGE 1987 (Ctd)	13
VALE GRAHAM CAMERON & MARS BAR COMPTETITION	14
FOR SALES, WANTED & CLUES	15
EVENTS CALENDAR	16

The President's Idle Chatter

Hi all,

Wow, the year is just flying by. April already. This means everyone should have renewed their membership (by March 31st) and it is AGM time.

Nominations for the Club executive and committee positions have closed and we have exactly the right number for all the positions. This means we don't have to have any voting and therefore will save some time at the April AGM.

Don't forget to bring along a plate to share after the meeting.

I went along to the All Ford Day recently and took my son and grandson. Grandson Rudy is 22 months old and shows great interest in cars, trucks, diggers.

We thought it was time to test his interest, with 1200 cars on display. He lasted over two hours sitting in the stroller and I was very impressed.

The venue in the Eastern Gardens is excellent, with lots of grass and shade, and well laid out. There was a huge display of vehicles and plenty of people looking in spite of the slightly drizzly weather.

For those that ordered the brimmed hats with the WDHVC logo, I will have them for the April meeting so bring along your \$20 and collect your hat. There are a couple of extras for anyone else that may be interested.

Stay safe and I hope to see you out and about.

David Mitchell



GENERAL MEETING MINUTES

MINUTES OF GENERAL MEETING No 621 OF THE WESTERN DISTRICT HISTORIC VEHICLE CLUB INC.
HELD AT THE CLUBROOMS ON TUESDAY 14th MARCH 2023

PRESIDING

President David Mitchell welcomed the 93 members, new members (Don, Colin, David) and our guest speaker, Lindsay Mole.

Our thoughts are with the families on the recent passing of Graham Cameron and Betty Jenkins.

APOLOGIES

Julie Wilby, Graeme Walker, Lindsay Rogers, Eva Barwise, Dallas Jones, David Perkins, Pat Evans, Brian Edwards, Sharyn Harris, Nancy McIntosh, Gus Shea, Graham Paech, Rhonda Alexander, Tim Paech, Simon Anderson, James Park, Jennie Green, Barb van Galen, Ken Jones, Jan Clissold, Jack Harman, Catriona Rowntree, John Bailey and Helen Graham.

Moved: Jim Coates

Seconded: Graeme Anderson Carried

SICK LIST

Gaylene Telfer

MINUTES

The minutes of the February meeting as published in the Backfire are confirmed as correct.

Moved: Graeme Baldock

Seconded: Max McKenzie Carried

CORRESPONDENCE (Fred)

INWARD

Letters In

- Nancy McIntosh - thank you card from Nancy and family for our thoughts on the passing of Duncan
- Graeme & Barbara Walker - thank you card for our thoughts on the passing of their daughter Sheridan
- Kevin Baker - his new address is Alan David Lodge

Emails In

- John & Rhonda Welsh- resignation from the club
- Showman's Bar - menu for lunch & dinner. Open every Thursday & Friday
- Federation - reminder of the Federation picnic at Mortlake 26th March

OUTWARD

Letters Out

- Don & Shirley Sell - new member welcome letter approved at the last Committee meeting
- Gary & Sadie McCredden - thanking them for their service to our club over the years

- Sympathy letters –

- ◊ Graeme & Barbara Walker on the passing of their daughter
- ◊ Ken Royce on the passing of his mother
- ◊ Nancy McIntosh on the passing of Duncan
- ◊ Helen Cameron on the passing of Graham

Emails Out

Nil

Moved: Rod Booley

Seconded: Ken Batson Carried

TREASURER'S REPORT (Maurice)

The Treasurer reported on receipts and payments since the previous meeting and submitted accounts to be passed for payment.

Moved: Maurice Healy

Seconded: Ken Parry Carried

PROGRAM DIRECTOR (David M for John)

No report this month. This month's guest speaker presented immediately before the meeting.

LIBRARY (David M)

David introduced our new librarian, Phil Abbott, to the meeting and thanked him for volunteering to take on the role.

Thanks again to Gary for his many years of service to the Club.

DINE OUT (Fred for Sharyn)

Ten members this month.

EDITOR (Jon)

Ray Matthews responded to the small WDHVC "badge" query in the last Backfire. The badges were made for trophies and cuff links.

WEBSITE (Damien)

No report this month.

FEDERATION REPORT (David P)

No report this month, but David will report on the recent Federation meeting at our next Club meeting.

COMMITTEE REPORT (David M for Tony)

The recent meeting discussed potential future member events.

MERCHANDISE (David M)

Please see David to order a Club branded wide brim hat.

TINKER DAY (David M for Dallas)

See the Backfire for details.

MARS BAR AWARD (Ray)

Not this month.

GENERAL MEETING MINUTES ctd

VEHICLE PERMITS (David M for Gus)

Ian Thomas answered David's questions on his 1972 Holden HQ displayed at the meeting. Ian ordered the car new in 1972, then sold the car, before buying it back a few years later. The car looks magnificent following a high quality recent cosmetic restoration.

RALLY REPORTS/EVENTS (David M)

See the Backfire for details on events when scheduled, including:

- Next Coffee Run to RACV Torquay Resort;
- The May Coffee Run will be to St Anthony's School in Lara;
- ANZAC breakfast at Barwon Heads; and
- BBQ in the bush.

Events attended by members include:

- The Anglesea Coffee Run was well attended as always: 11 old and classic member's cars.
- Trevor had a great day at the recent Tinker Day viewing Stuart Harvey's wonderful collection.
- Lindsay enjoyed the recent Tech Night on exhausts particularly the "Hoon" valve (tempted to be the first Hillman Imp in the street with one fitted?).
- Ken won the Best Original trophy at the Colac Car Show.

LONG DISTANCE RALLY (Sharyn)

No update. Likely to be in the Griffith area in September.

TECH NIGHT (Peter)

All Things Motorbike at the next tech night.

SWAP MEET (David M)

More volunteers needed!

KITCHEN (Pam)

No report.

GENERAL BUSINESS

- Kevin Wilby attended the Kalorama 60th Anniversary.
- 25th year membership badges presented to David Little and Kevin McBain

FOR SALES, WANTED & CONFESSIONS

Our Editor as brought a Mercedes Benz 190E from within the club.

Meeting closed.

Next meeting to be held at 7.30pm on 11 April 2023 in the clubrooms.

- Leigh Dwyer



NOTICE OF ANNUAL GENERAL MEETING

All members are notified that the Annual General Meeting (AGM) of the Western District Historic Vehicle Club Inc will be held at the clubrooms on Tuesday, 11 April 2023.

The AGM will follow the monthly general meeting, which commences at 7:30pm.

Members please bring a plate of supper to make it a successful social evening.

AGM Agenda

- approval of minutes of 2022 AGM
- President's report
- Secretary's report
- presentation of the Annual Balance Sheet and Statement of Accounts for the 2022/2023 financial year
- election of Auditor
- confirmation of Committee.

The following executive and committee nominations were received up to the end of the general meeting on 14 March 2023.

- **President** – David Mitchell
- **Vice President** – John Bailey
- **Secretary/Public Officer**, Consumer Affairs notification of Incorporated Association – Fred Harris
- **Treasurer** – Maurice Healy

The following nominations were received for the general committee.

- Graeme Anderson
- Simon Anderson
- Jon Breedveld
- Tony Brincat
- Col Jordan
- Ken Parry
- Gus Shea
- Barbara van Galen

As the nominations did not exceed the vacancies, a ballot will not be required.

Fred Harris
Honorary Secretary

ANNUAL GENERAL MEETING MINUTES 2022

MINUTES OF ANNUAL GENERAL MEETING No 55 OF THE WESTERN DISTRICT HISTORIC VEHICLE CLUB INC. HELD AT THE CLUBROOMS ON TUESDAY 12th APRIL 2022

PRESIDING : Vice President John Bailey welcomed 70 members to the AGM.

APOLOGIES

Fred Dossier, Barry Johansson, Alan Tipper, Graeme Anderson, Rod & Lorraine Roach, Joan Stott, Darryn Tucker, Alex McLaws, Tiny Stonehouse, Lindsay Rogers, Len Miller, Paul Strickland, Eva Barwise, Max Richards, Graeme Peacock, Nick Neeson, David Mitchell.

Moved: Dallas Jones

Seconded: Barb van Galen Carried

SICK LIST

None

MINUTES

Minutes of the 54th Annual General Meeting held on April 13th 2021 were confirmed as a correct record.

Moved: Libby Booley

Seconded: Brian Edwards Carried

REPORTS

The President and Secretary presented their Annual Reports, to be published in the *Backfire*.

TREASURER REPORT Maurice

The Treasurer read the statement of incoming and outgoing expenses as compiled by our auditor, Gary Harbert, which is available for members to review.

Moved: Maurice Healy

Seconded: Libby Booley Carried

Maurice moved that the auditor be re-appointed.

Moved: Maurice Healy

Seconded: Max McKenzie Carried

ELECTION OF OFFICE BEARERS

Vice President John vacated the Chair and introduced life member Trevor Schneider who took the Chair and thanked all the office bearers for their work over a challenging year.

Trevor noted that James Park, Rod Booley and Dallas Jones had chosen not to re-nominate for a Committee position. He thanked them for their support and contribution to the club.

All executive positions were declared vacant. Committee nominations did not exceed the positions available and so no vote was necessary.

The successful nominations were:

President: David Mitchell

Vice President: John Bailey

Secretary / Public Officer, Consumer Affairs Notification for Incorporated Association:

Fred Harris

Treasurer: Maurice Healy

General Committee:

David Perkins, Barb Van Galen, Gus Shea, Tony Brincat, Col Jordan, Jon Breedveld, Graeme Anderson.

PRESENTATION OF TROPHIES

John resumed the Chair and thanked Trevor for his assistance.

Jon Breedveld was named as the Club Member of the year for his Editor role over the last COVID year. Jon thanked the Club for the award and took the opportunity to thank Gus Shea for his continuing service to the Club.

25 year membership badge presentations were held over until a future meeting.

Meeting closed at 8:45pm.

25 Year Badges Presented

At the March meeting, 25 year membership badges were presented to David & Loretta Little and Kevin & Robyn McBain, with David and Kevin accepting the awards on behalf of the respective couples.



Kevin (left) studies his award, while the two Davids (President & Little) smile for the camera (right).



The April Answer to the March Mystery



This is a story that finishes where it started. It is also a cautionary tale about what can happen when you accumulate more than you can remember that you own. To explain: the March *Backfire* included an appeal for information about the age and intended use of this little enameled WDHVC badge. Those at the March meeting heard from Ray Matthews that the badges had been included on early presentation trophies and came in two sizes: one about half an inch in diameter and the other about one inch. Ray said the smaller example was also used for cuff links. Evelyn Hill (who had supplied the original battered little badge and posed the initial question about its origins) said that his recent research suggested it may have also been used on the handles of tea spoons. All of these items were among the club merchandise of their day, and were possibly sold as early fundraisers.

All very useful and interesting information – seemingly quite sufficient to answer my “Not the Mars Bar Competition” query.

Now most WDHVC members are collectors to some degree. Some more disciplined souls limit their collections to those parts they require for their current vehicle restoration. Others may have the odd box or shelf containing bits that they might just need for the next resto, or as spares their current vehicle.

But let's be honest – most of us have more than one vehicle and are not as disciplined as the people described above. We have a varying number of boxes, shelves, sheds or shipping containers, filled with what is variously described as “barn finds”, swap meet bargains, precious spare parts or bits for future projects.

Or, less kindly, by those who do not understand, as scrap iron or junk!

There are even some (so I am told) whose collecting is not limited to vehicles and vehicle memorabilia. Their eclectic tastes, fascination with machinery of all sorts and keen sense of history mean they have accrued items of all types. Throw in a strong desire to preserve the past, so that it may be understood and appreciated in the future, and you have a potent recipe for random accumulation.

It is fair to say that Mr E Hill is one of these people. His aggradation of items has extended well beyond his interest in T-model Fords, Republic trucks and the Norton Cezaire. So, having prompted the original question, Evelyn went back to his shelves and very early editions of the *Backfire*, and began investigating.

Between Evelyn and Ray they have established that there must have been a run of the two little badges ordered by the Club in its very early years. Meeting Minutes suggest that both the first version of 3 inch diameter badges used on cars (known as the “saucepan lid”) and as plaques, and the little badge that caused this all this probing, were ordered in the early 1970s, only a few years after the Club beginnings in 1967.

Apparently 100 individually numbered large badges arrived in Dec. 1971. In Feb. 1972 badge Number 1 was offered to Mr Henry Jacobs, the club patron. Club founder Dave Doman was given badge Number 2 and the designer of the badge, Ian Smith, was given badge 100. In June 1972 there are reports of the lapel badges being ordered in batches of 20.

President Warrick Gillin referred to the possibility of cuff links being made from the current lapel badges in Oct. 1972. So the lapel badges (the half inch version of the badge with a stick pin attached) existed before then.



A financial statement from 1973 includes income of 119 pounds 50 pence from the sale of “car and lapel badges.” - a healthy sum from what must have been popular items.

By October 1974 *Backfire* was advertising “Xmas Gift Ideas. Club badges \$1. Cuff links \$3. Radiator badge \$4 plus old type radiator badges \$1.”

Despite his original claim that he did not know about the badge, Evelyn's rummaging through his own collection revealed that he actually owns examples of a key fob, both gold and silver tea spoons (some in their original cardboard sleeves and silk-lined presentation boxes) and cuff links – all containing the little club badge!



So to go back to the beginning of this story: when you ask about an item, claiming not to know of its origins, perhaps it may be best to first have a good look through your shelves and rediscover things that you had forgotten you owned.

My thanks to Evelyn and Ray for enabling me to photograph some for the early items shown here.

I hope this tale has prompted some memories of the early days for our long-standing members and caused some light-hearted reflection on the whereabouts, necessity and intended purpose of the many collections we seem to have acquired over the years.

PS: having discovered club memorabilia that he didn't know he had, Evelyn has offered his pieces for display in the club rooms, and the Committee has accepted his offer. Now to find a suitable spot in a display cabinet for them! Watch this space.

- Ed



The “five cent” and “ten cent” versions of the badge, as used on trophies.

Memberships are now overdue ...

WDHVC membership fees were due on 31 March 2023.

A significant number of members have not yet renewed and they are now **unfinancial**.

If you have not yet renewed, please complete the Membership Renewal Form (available at the club rooms and sent to most members by email or post) and **post it** to the Treasurer with a \$55 cheque.

Postal address:

The Treasurer,

WDHVC Inc

PO Box 200 NEWCOMB VIC 3219.

Membership renewal for postal applications is \$55.

Red-plated cars registered cannot legally be driven on the roads until memberships are renewed.

If you no longer wish to be a member, please either email or post your resignation to the Secretary.

You haven't experienced true heart-break until you have been thinking about leftovers all day and then come home to find someone ate them!

Western District Historic Vehicle Club Inc Presents

GEELONG BAY CITY SWAP MEET

Sat 13th May 2023 Gates open 7am

Geelong Showgrounds (Melways Ref 452 E10)



Costs:

*Gate entry: Adult/Teenage \$10 per person, Under 13 yrs Free

*Outdoor site: \$20 per 10 x 6m site + gate entry costs per person
(no booking required for outdoor sites)

*Limited indoor sites Booking req'd. Call/email for details/availability

*Area for display and sale of special interest vehicles

(\$20 per car and gate entry costs per person)

*Parking for non sellers at Geelong Racecourse, Breakwater Rd.

*Geelong Mobile ATM facilities on site

Friday night: Camp sites available for stallholders only.

Entry from 5pm. Gates will close at 9pm sharp. (site + per person entry costs)

Rules: Strictly no animals allowed in showgrounds.

No fires permitted in any way. No unauthorised food/drink vendors.

No riding of a bicycle, scooter, motorcycle or rec vehicle.

Disability scooter permitted but must not exceed 4kph.

Updates: on the Geelong Bay City Swap Meet Facebook page

Contact: email: secretary@wdhvcgeelong.com

Ph: 0417 306 177 (no texts)

WDHVC PO Box 200 Newcomb Vic 3219

Other Events

Source: [swap-meets\(ozwrenches.com\)](http://swap-meets(ozwrenches.com)) and individual event flyers

Apr 1 2023	Horsham Swap Meet	Horsham Market and Swap Meet, Saturday, Showgrounds
Apr 2 2023	Castlemaine Swap Meet	Camp Reserve, Castlemaine, Sunday,
Apr 2 2023	Scoresby Motorcycle Swap Meet	Scoresby Motorcycle Only Swap Meet, Nat Sr/team Centre, Scoresby
Apr 2 2023	Maffra Swap Meet	Gippsland Vehicle Collection, Maffra
Apr 16 2023	Kerang Swap Meet	Kerang Showgrounds
Apr 16 2023	Lancefield Swap Meet	Lancefield Park Chauncey St. Contact Pam 0414 491 749
Apr 16 2023	Mirboo Nth Motorbike Swap Meet	Mirboo Nth Motorbike Only Swap Meet
Apr 22 2023	Echuca Swap Meet	Echuca Rotary swap meet, Saturday 22 April, 0483 230 908
Apr 30 2023	Colac Swap Meet	Colac Showgrounds. Contact 0428 394 249 gandproseevents.com
May 7 2023	HTPAA Antique Hand Tool Market	St. Anthony's School Hall, 164 Neerim Rd, Caulfield East
May 13 2023	Geelong Swap Meet	Geelong Showgrounds, Breakwater Rd. Gates open 7am. secretary@wdhvcgeelong.com
May 20 2023	Wedderburn Swap Meet	Wedderburn Vic
May 21 2023	Lockington Swap Meet	Lockington, Vic
May 27-28	Historic Winton.	Winton motor Raceway, Benalla, Victoria. Details www.historicwinton.org
Jun 10-11 2023	Daylesford Collectables Fair	Daylesford Town Hall
Jun 11 2023	Maldon Swap Meet	Maldon Racecourse Reserve (Vic)
Jun 25 2023	Fridge Swap Meet	Armstrong St South, Ballarat .
Sept 10 2023	Shepparton Swap Meet	GVMVDC Swap Meet, Shepparton Showgrounds
Aug 28 to 1 Sept	Federation Open Tour	from Marong through Kerang, Swan Hill, Echuca and Shepparton. Spend time spend in the recent flood affected areas of northern Victoria and support their rebuilding efforts. Activities planned include museum visits, private tractor and bowser collections, Echuca Beer Shed and Shepparton attractions.
Nov 11 & 12	Bendigo National Swap Meet.	Entry: Sat only \$15. Sun only \$5. Children 15 and under free. Public: Gates open Sat 6 AM. Sun 7 AM. Sheds open 7 AM. Details www.bendigowrap.com.au . Site bookings 0427 446 660. General enquiries 0434 730 822. info@bendigowrap.com.au
Nov 18-19 2023	Daylesford Collectables fair	Daylesford Town Hall

Events Calendar

Updates will be sent by email and posted on Facebook.
(Please pass on to those without email addresses.)

With both the Flu and Covid in the community, masks are recommended when in close proximity to others.



Thursday 6 April, Coffee Run RACV Torquay Resort, 1 Great Ocean Rd Torquay, from 10am. Hopefully there will be scones and cream available, subject to the good humour of the "cook." Park in the carpark on the front entrance side or proceed to the end of the carpark and head to the undercover carpark where a lift will take you up to the ground floor. Enjoy!

Contact: Col 0425 822 026

Tuesday 11 April General Meeting 7.30pm in Clubrooms. Followed by the **AGM**

Wednesday 12 April Dine Out The Shell Club 6pm. Please call Sharyn 0417 546 089.

Tuesday 18 April Committee Meeting 7.30pm in clubrooms.

Thursday 20 April Tinker Day will be to Graham Peacock's place in Drysdale for a look at what keeps him amused. Those in the local area may like to go straight there. Otherwise, be at the clubrooms before 10 o'clock as we will be departing smartly at 10. Contact: Dallas 0432 172 171.

Monday 24 April April Backfire Deadline 5pm. Contact: Jon B 0417 311 441

Tuesday 25 April ANZAC Day BBQ at Barwon Heads. Meet at the clubrooms 8.30am. **SUPPLIED** - bacon, eggs, bread, boiling water, tea, coffee, sugar, milk and the kitchen sink. **BYO** - table, chairs, crockery, cutlery and anything else you require. If you want to bring something to cook and stay for lunch, the BBQ will be there for your use until after lunch. Please add your name to the list at the meeting or ring Murray so we can organise our catering purchases.

Contact: Murray 0409 841 700

Tuesday 25 April Tech Night "Lubrication." A slippery topic at the best of times. It may take a little grease to get the wheels turning, but the conversation is likely to flow unfiltered before long! And remember: "Oils ain't oils, Sol!" All welcome. Wear your name badge and get a FREE CHOCOLATE FROG! Be there at 7pm, so we can set up for a 7.30pm start.

Contact: Peter Telfer 0427 526 938.

Friday 28 April Backfire folding morning 9am Clubrooms.

Contact: Peter Telfer 0427 526 938

Thursday 4 May Coffee Run Will require a special effort by members with old cars as we have been asked to attend St Anthony's Primary School at 90 Kees Rd Lara on 4 May to display our finest vehicles. The Principal has kindly offered to provide morning tea/coffee for all that attend regardless of the vehicle you arrive in. Numbers will be required for catering purposes for this run.

Contact: Col 0425 822 026

Saturday 13 May Geelong Bay City Swap Meet Showgrounds

Contact: Fred 0417 306 177

Thursday 18 May Tinker Day will be to another club member's place who has kindly offered to show us what keeps him amused. Details to follow next month

The 2023 Bay City Swap Meet is ON! Put 13 May in the diary.

BUT this will be our Club's LAST Swap UNLESS a new Swap Director and more helpers volunteer.

Help Needed. Tinker Days for July, August and possibly September have not been filled. I am looking for some ideas and someone to organise and run Tinker Days for these months, as I will be away. Please let me know if you can help out. Contact: Dallas 0432 172 171.

Vintage and Classic Car Club Ballarat - Lake Bolac Camp Out. Wed 17 to Tues 23 May

Come and enjoy camping for six nights (or less if you can't stay the duration). Meet other car club enthusiasts.

Venue: camping area on the lake called **Picnic Point**, about 1km PAST the Lake Bolac Caravan Park. Sites are free but unpowered. (An amenities block has power.) Covered BBQ. \$5 showers. Open to any members with caravans (vintage or modern), motorhomes, campervans, tents, swags or whatever. Wear your club name badge for easy intros. Come to dinner on Friday at the local hotel (book with **Nerene** first please) or at the camp fire on site.

For details call **Nerene** on 0427 348 060 or **Mike** 0419 935 147

(or WDHVC member Brian Edward, who went last year)

RALLIES & RUNS

February Tinker Day – Stewart Harvey’s Collection

The chance to visit Stewart Harvey’s lovely home and gardens, and to see his impressive collection of vehicles drew 51 members to Moriac for the 8 February Tinker Day run. This impressive turnout was rewarded with pleasant weather and a very worthwhile outing. Members drove an interesting array of club cars to the event, with Peter Everett’s 1938 Mercedes arousing particular interest on its first club run.

Stewart’s collection ranged from a farm truck he had recently bought from Eric Lewis to a beautifully restored replica of a truck used by his father in the Harvey's Transport business, and a very sporty Aston Martin - with lots of others as well.



RALLIES & RUNS

February Tech Night Exhaust Systems

Exhaust systems are a compromise between the flow of exhaust gases and the amount of noise escaping from the engine.

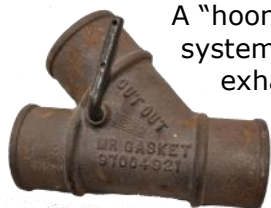

A "hoon valve" allowed the exhaust system to bypass the silencer, directing exhaust gases to the outside, reducing back pressure and creating more noise pollution. They are not street legal!

The Packard silencer was super-sized, being very heavy and filled with asbestos and lead wool. This was very effective but did not last long because the lead melted. The silencer was very heavy and long.

A homemade fishtail exhaust for a vintage motor cycle was shown and the home made tools and dies used to make it. The owner also imported and exhaust system for a vintage motor cycle from the UK but it did not fit.

A large tractor silencer was shown.

There was a lot of talk about catalytic converters. A hot converter caused a fire at an event car park, destroying many cars. Catalytic converters are easily damaged and stop working. Modern cars now have two sensors in the exhaust system, one before and one after the converter, to make sure it is still working. Because of the external location and the use of valuable precious metals, including platinum, palladium and rhodium, catalytic converters are a target for thieves.

The discussion got onto electric cars and some members agreed with the February 2023 article on electric cars.

This is only a short summary of what happened: come along next time and hear the full story.

- Lindsay Alford

March Feature Car - 1972 HQ Holden Sedan

Ian Thomas displayed his 1972 HQ Holden Premier sedan in the garage at the March meeting. Ian said that he had bought the car new, then had to wait for 3.5 months for delivery while the option pack he had specified was assembled.

He said the car cost him \$4,200 on the road in April '72. Options included a 4-speed gearbox, bucket seats and sports wheels. AC was fitted 10 years later. The car was supplied by Anketell Motors in Drouin and Ian still has his original purchase documents.

In 1984 he sold the Holden to his neighbor's son - for \$4,200. Some three and a half years later, he bought the car back again, again for \$4,200. A body-off full restoration followed and the car as displayed was still in faultless condition. It has now done 430,000 kms, with new rings and a valve grind having been done at 300,00kms.

Ian did admit that, had he known that the Holden Monaro was soon to be released, he would have bought that instead of his 253 V8 Premier model.



The 1987 World Solar Challenge

Lindsay Mole was the guest speaker at the March meeting. Both he and President David Mitchell were in the Ford team at the first World Solar Challenge in 1987. The event ran for 3022 kms, from Darwin to Adelaide, with 23 teams entered. Fourteen vehicles finished: the Holden team won and Ford came second.

Lindsay said that the idea for a solar powered race came from adventurer Hans Tholstrup. Among his many adventures, Tholstrup became the first person to circumnavigate Australia in an open power boat in 1970. In 1972, Tholstrup rode a Yamaha RT 360 two stroke motorcycle across Australia from Rockhampton to Perth with minimal supplies and support. In 1975, he flew a Grumman Trainer fixed wing aircraft solo around the world.

Tholstrup thought of the World Solar Challenge after making the first transcontinental journey in a solar-powered car, "The Quiet Achiever". He went from Sydney to Perth in 20 days in 1983 with co-driver, Larry Perkins.

The rules for the first solar challenge race included an 8m² size limit for the solar array. On board batteries were allowed but could not be changed during the race. Cars could only be driven between 8am and 5pm and teams camped on the side of the road. Scrutineers accompanied each car. Teams could charge their batteries from the sun for two hours at either end of day – if there was sunlight! There was a vehicle safety check in which entries were passed by a semi-trailer at 80kph, to ensure their stability. Race start positions were determined by the fastest speed achieved before the race.

The Ford Team had some experience in previous competitions, with the Mileage Marathon Competition for best MPG, and had set world records (5107 mpg).

A group of Ford engineers, (mostly Mechanical and a couple of Electrical) volunteered their time and entered the Solar Challenge. The team had some use of Ford facilities and a little financial support from Ford. Their entry "The Sunchaser" was built in Lindsay's double garage in East Geelong.

Race rules were developed by Hans Tholstrup with Ford input in the lead up to the race.



A younger Lindsay Mole clammers out of the "Sunchaser", in his garage in 1987



As the race got closer GM announced they were entering with a team run by Aerovironment and assisted by Hughes Aerospace (owned by GM). Their vehicle would use the world supply of the then most efficient Gallium Arsenide solar cells.

In response to this announcement, Ford Management found some extra cash to fund the Ford entry – about \$400k for a car built mainly by volunteers, compared to GM's \$7million budget and professional build.

Lindsay said that a mule was built to test stability and handling. The body was made of Kevlar, it used a rare earth magnet electric motor and silver zinc batteries. One design problem was that the enclosed aerodynamic body caused the driver to overheat. A one inch hole was drilled in the tip of the car, with air pressure forcing enough air into the cockpit to cool the driver. Another furphy perpetuated by the press while testing the prototype at 3am (for secrecy) was that the car ran on moonlight!

The decision was made to use a tilting solar panel to maximise the solar input as the sun moved across the sky. The extra weight and extra drag of this arrangement would be offset by the extra solar energy harvested. It also gave the unexpected benefit of being used as a "sail" on occasion, providing incidental wind power to propel the Sunchaser.

The first public test run of the car was at the official opening of the Melton Bypass on the Ballarat Freeway. This made the TV news but did cause a few teething troubles. The car used only battery power at this event.

Each entrant had a support crew. Both Ford and GM had included a weather vehicle in their crews, to provide forecasts which could help in planning race strategy. Sadly the equipment in the Ford weather vehicle didn't work, so the team was not aware of the rain storms that were

The 1987 World Solar Challenge (ctd)

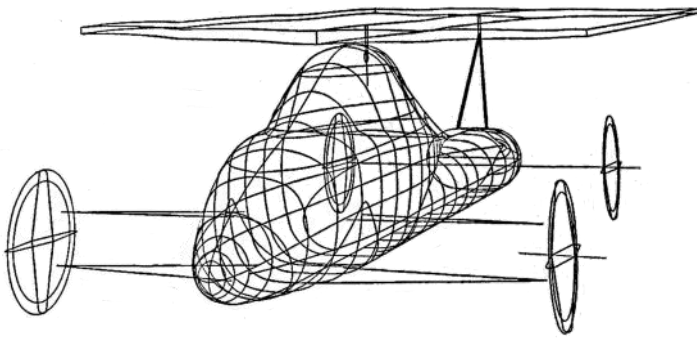

Design concept drawing of the "Sunchaser"

looming shortly after the race began. The GM team did see the weather forecast and the expected storms approaching. As a result GM ran their car flat out on battery power to get down the road beyond the reach of the rain.



Others were not so lucky and the resulting wet pretty much sank the chances of winning for the remainder of the field.

When the race reached Alice Springs, a Swiss team, "The Spirit of Biel" was running second, with the Ford team third. Unfortunately the Swiss collided with a conventional car at a

roundabout, becoming the first solar powered vehicle in a car accident.

While this was sorted out, the Ford "Sunchaser" passed them and retained second place for the remainder of the race.

Being the first such event, there was much to learn. From 1987, the Solar Challenge has run every second year until 2019, when Covid caused a pause. The next event is next due in October 2023. The rules have been tweaked along the way and teams have benefitted from previous experience, better funding and much improved technology.

Lindsay said although they were "flying by the seat of their pants" in this first event, they had a great time and learnt from the experience.

Issues encountered included

The Sunchaser bicycle-type derailleur gearbox hadn't been tested before the event and wouldn't select at the start of the race, so the car was run in third.

No weather forecast meant they suffered thunder-storm damage. The GM entry got ahead of the weather and had a sunny run all the way)

Tyres had some failures at the recommended 100psi. This was fixed by dropping pressure to 90psi.



After the day's racing, the tilting solar panel was removed at the roadside camp and pointed towards the last of the sun, to charge the battery. The helicopter raising dust was Dick Smith checking the opposition to his Aust'n Geographic entry

Links:

The start of the 1987 race in Darwin.

<https://www.youtube.com/watch?v=R40jn9RoRjQ&t=5s>

[World Solar Challenge - Wikipedia](#)

[Overview | World Solar Challenge 2023](#)

Material reproduced with permission from Lindsay's presentation slides. - Ed

The Results: 13 cars finished. Only the first six times were recorded

Rank	Team	Nationality	Car Name	Race time	Av Speed KPH/MPH
1	General Motors	US	Sunraycer	44hrs 90mins	66.9/41.57
2	Ford Australia	Aust	Sunchaser	67.53	44.48/27.64
3	Ingenieurschule Biel	Swiss	Spirit of Biel	69.97	42.94/26.58
4	Aust'n Geographic	Aust	Marsupial	81.43	36.89/22.92
5	Charles Darwin Uni	Aust	Desert Rose	95.45	31.47/19.55
6	Chisholm Institute	Aust	Desert Cat	98.20	30.59/19.01

VALE – GRAHAM CAMERON

Sadly, Graham passed away on 1 March 2023 after a battle with melanoma.

On leaving school, Graham entered an apprenticeship at CSIRO, division of textile industry, as an engineering fitter, where he joined a team involved with design of new approach machinery

to replace the traditional machines of yesteryear.

As a qualified tradesman he found employment in various engineering firms, including Winchester Ammunition at Pt Henry.

He met and married Helen, who was a member of the CSIRO staff at Belmont.

Graham and Helen joined our Club 18 years ago and have been active members, regularly attending meetings and rallies. In March 2018 they hosted a Tinker Day at their Grovedale home.

His vehicles included a 1971 VW Beetle, 92 Toyota Land Cruiser, 99 Ford Laser & 69 Mercedes 280.

Graham volunteered for several organisations including Coastguard, Bancoora Surf Lifesaving Club, Red Cross First Aid Team, and as a patient transport vehicle driver for Red Cross and the Geelong Hospital.

We extend our sympathy to his wife, Helen, their two daughters and the extended family.

Compiled by Ray Matthews and Trevor Schneider



Graham's '71 Beetle at the 50th Anniversary display in 2017

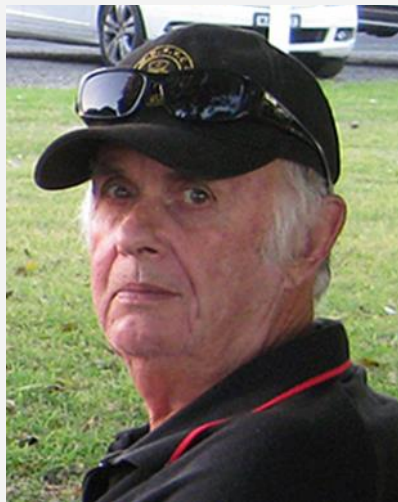

Great Mars Bar Competition

The April Competition



Well folks, this will be a hard one for us all. Our member in question is the third child from the front, sitting on the horse.

His dad and brothers are the rest of the team in the photo.

We also need to guess the name of the horse (a girl horse name) for a second Great Mars Bar on offer this month. Just think, TWO Great Mars Bars up for grabs in one evening! Good luck!

- Ray van Galen

More photos needed

Please sneak in your photo submissions to:

Ray van Galen

Ph 52789 368,

or

email rbvangalen@gmail.com



Childhood Injuries

Fell off my bike

Fell out of a tree

Twisted my ankle

Adult injuries

Slept wrong

Sat down too long

Sneezed too hard

Life Quotes

"They say marriages are made in heaven. But so is thunder and lightning" - *Clint Eastwood*

The views/comments expressed in the publication of this newsletter are those of the individual contributor and are not necessarily endorsed by the current Committee of the Club. Whilst every care is taken to determine the safety of any technical information provided and the accuracy of the information supplied for inclusion in this newsletter, it is printed in good faith and neither the Committee nor the Club accept any responsibility for any loss or injury incurred by any application of such information.

FOR SALES, WANTED & CLUES

For Sale

For Sale 1940 Packard. Straight 8

Man. 3 speed + overdrive. 6 wheel equipped.
Leather interior.

Travelled about 20,00kms
since ground up resto

6 years ago. On club
plates: 6233-H9.

Asking \$55,000.

Call Tony on 0437 453 259.



3/23

.....

For Sale VP Commodore Station Wagon In VG

condition. Reg. 81739-H. 252,000 kms. \$6,500.

Call Dick 0417 393 139.

2/23

Wanted

Wanted An external sun visor to suit a 40s
era car. It needs to be 53 inches [1.35 m] across
and have the windscreen centre pillar attachment
point. Call Karl 0413 074 733.

3/23

.....

Wanted. Early vacuum fuel tank,
any make, for current
project. Call Paul 0417 39 0027 [the-
trady@outlook.com](mailto:the-trady@outlook.com)

2/23



KEEP IT IN THE CLUB

Got a vehicle for sale?

**Please consider advertising it in
Backfire first, to give your fellow
members the first option of buying.**

For sale/wanted ads are free to Members and generally
appear for **two issues** of *Backfire*. To remove
advertisements from the newsletter earlier, email
editor@wdhvcgeelong.com (Ph 0417 311 441).

Reminder: All vehicles in the "For Sales" must have
VIN number & Price or Registration Number & Price,
otherwise they will be listed under "Clues". Ads for the
'Clues' section must not refer to any payment that may
take place by mentioning an amount or 'best offer', etc.

All ads for cars also appear on the **club web site** where
greater detail and photos (where supplied) can be
viewed. To see ads, go to

<http://www.wdhvcgeelong.com/wdsale.html>

**All ads remain on the website until you request
their removal.** To remove an ad from the
website, email webmaster@wdhvcgeelong.com
(Ph 0418 587 415).

FOR SALES, WANTED & CLUES

For Sale

For Sale T.O.M.M. A large quantity of T.O.M.M.
[The Old Machinery Magazine] magazines. Ideal
for filling gaps in collections. They go back more
than 20 years and are in mint condition. \$3 each.
Call Karl 0413 074 733.

4/23

For Sale Land Rover Discovery TDI 300

Reg. NHP 029. Manual. 1995. 3-door wagon.
Gen.290,000+kms. Motor untouched – doesn't use
oil. Bull bar & side steps, dual batteries, 12/240
volt in rear. Tow bar, brake controller & Anderson
plug. New Pedders coils & airbags. 2 CB radios.
Air compressor. New clutch @ 145k
With books and full service history. \$10,000 ONO.
Call Bernie 0422 773 558.

4/23

GRAND SALE! GRAND SALE! GRAND SALE!

All club members and interested enthusiasts are invited to
the **shed clearance sale of the late Barry Collinson**

5 Hayman St, Portarlington

Saturday, 15 April 2023

9.am to 3 pm

- * hand tools | * engineering tools | * carpentry tools
- * electrical tools | * powered tools |
- * books and magazines | * storage cabinets
- * assorted spare parts for various marques
- * much, much more

All items must go: prices are by agreement. (There is too
much to individually price them.)

Transportable items must be removed by 3 pm on the day

Cash and tap payment options available

This sale is being co-ordinated by the Bellarine Historic
Vehicle Club on behalf of Lorraine Collinson.

Enquiries to Stewart Garmey, 0457 310 220,

PAID YOUR MEMBERSHIP?

**Membership renewal fees were due by
31 March. If you have cars carrying Red
Plates that are registered through our club
and we haven't received your completed
membership renewal form and money by
31 March, VicRoads considers those cars
to be unregistered and you cannot legally
drive them on public roads.**

**If you no longer wish to be a club member,
please email or post your resignation to
the Secretary, Fred Harris.**

If undeliverable return to:

WDHVC
PO Box 200
Newcomb VIC 3219

Backfire

PRINT POST
APPROVED
PPN 1000/19091

POSTAGE
PAID
AUSTRALIA



April 2023

1950s Morris Minor 1000

Sunday	Monday	Tuesday	Wednesday	Thursday	Friday	Saturday
26 EXTREME WEATHER (including Total Fire Bans) A club event may be cancelled on extreme weather days. If an extreme weather day is predicted members should either: check the club website; check their emails; or contact the event organiser.	27	28	29	30	31 March <i>Backfire</i> Folding Morning	1 Horsham Swap
2 Castlemaine, Scoresby & Maffra Swaps	3	4	5	6 Coffee Run.  10am RACV Torquay	7	8
9	10	11 AGM & General Meeting, 7.30pm	12 Dine Out Shell Club	13	14	15
16 Kerang, Mansfield & Mirboo Nth Swaps	17	18 Committee Meeting	19	20 Tinker Day 10am Clubrooms	21	22 Echuca Swap.
23	24 <i>Backfire</i> Deadline	25 Anzac Day BBQ Bwn Hds. Tech Night "Lubrication"	26	27	28 <i>Backfire</i> Folding Morning	29
30 Colac Swap	1 May	2	3	4 Coffee Run.  10am St Anthony's PS Lara	5	6